

Instructions Manual

Tektronix

**THM500 Series
Instruments**

070-9857-01



Table of Contents

THM500 Series Instruments	1
THM500 Series Specifications	3
THM500 Series Performance Verification	9
Test Equipment	10
Functional Test	11
DMM Verification	12
Oscilloscope Verification	15

THM500 Series Instruments

The Tektronix THM500 Series instruments combine the features of a complete digital multimeter (DMM) with the power of an oscilloscope, all in a single package.

The DMM portion of these instruments measure true RMS AC and DC voltage, resistance, continuity with audible mode, and a diode test.

The DMM portion also includes the following features:

- A hold feature to freeze the display
- MIN and MAX readouts to track instantaneous signal variations from the last held value (Δ Hold)
- AC and DC current measurement with optional current probe

The oscilloscope portion of the instruments feature an autoranging mode that completely automates operation. In this mode, a usable signal is always displayed without operator intervention. If desired, you can switch to manual mode by selecting any control. In manual mode, you can specify general oscilloscope operations such as coupling, triggering, and acquisition modes.

THM550, THM560, and THM565 models include preconfigured modes to set up the oscilloscope for motor testing, transformer THDF measurement, power line monitoring, and power measurement. The THM57x series instruments include preconfigured automotive test setups.

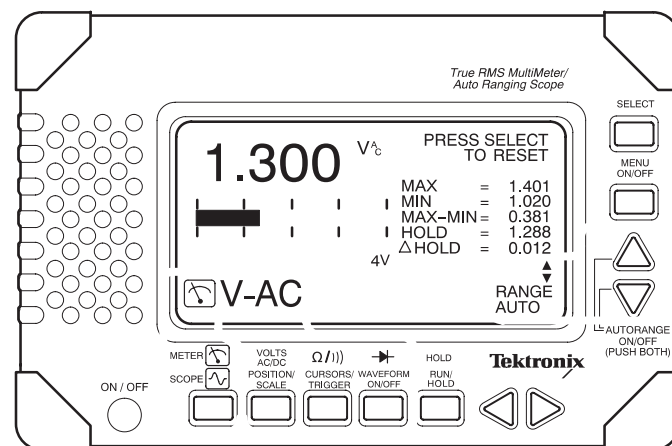

Figure 1: THM500 series instrument

THM500 series instruments will also store waveforms, settings, and displays. With these features, you can do the following:

- Recall settings
- Automate test procedures
- Save waveforms and screens in the field for later analysis
- Transfer waveforms and screens to a personal computer (requires optional communications adapter)

THM500 Series Specifications

The characteristics listed in this section apply under the following conditions:

- The instrument operates within the environmental conditions specified in Table 4 on page 8, unless otherwise noted.
- The instrument warms up for at least 5 minutes.

NOTE. All specifications are warranted unless marked “typical.” Typical characteristics are not guaranteed but are provided for the convenience of the user.

The specifications listed for the THM565 also apply to the THM57x series except as noted in Table 1.

Table 1: How THM565 and THM57x series products differ

	57x	565
Modes		
Line Test		•
Motor Test		•
Automotive preconfigured test setups	•	
Vertical		
Mathematics capability		•
Invert capability		•
Measurements		
Voltage Measurement		•
Timing Measurement		•
Power Measurement		•
THDF Measurement		•
Automotive Measurements (preconfigured test setups)	•	

Table 2: DMM specifications

		550	560	565
General				
Resolution	3¾ digit (4000 count) full-scale reading except as noted	•	•	•
Input Impedance (Typical)	VDC or VAC: 10 MΩ (<10 pF; <70 pF at 400 mV range)	•	•	•

Table 2: DMM specifications (cont.)

		550	560	565														
General																		
Additional Readouts	MIN: Minimum voltage or resistance MAX: Maximum voltage or resistance MAX-MIN: Difference between MAX and MIN HOLD: Value of the main reading when the HOLD button is pressed Δ HOLD: Difference between HOLD reading and active reading	•	•	•														
DC voltage																		
Range and Resolution	<table border="1"> <thead> <tr> <th>Range</th> <th>Resolution</th> </tr> </thead> <tbody> <tr> <td>400 mV</td> <td>0.1 mV</td> </tr> <tr> <td>4 V</td> <td>1 mV</td> </tr> <tr> <td>40 V</td> <td>10 mV</td> </tr> <tr> <td>400 V</td> <td>100 mV</td> </tr> <tr> <td>850 V</td> <td>1 V</td> </tr> </tbody> </table> <p>Autorange available; selects from all ranges except 400 mV.</p>	Range	Resolution	400 mV	0.1 mV	4 V	1 mV	40 V	10 mV	400 V	100 mV	850 V	1 V	•	•	•		
Range	Resolution																	
400 mV	0.1 mV																	
4 V	1 mV																	
40 V	10 mV																	
400 V	100 mV																	
850 V	1 V																	
Accuracy	$\pm(0.5\%$ of reading + 5 counts)	•	•	•														
Normal Mode Rejection	>60 dB typical at user selectable 50 or 60 Hz	•	•	•														
Common Mode Rejection	>100 dB typical at user selectable 50 or 60 Hz	•	•	•														
AC voltage																		
Range and Resolution (True RMS)	<table border="1"> <thead> <tr> <th>Range</th> <th>Resolution</th> </tr> </thead> <tbody> <tr> <td>400 mV</td> <td>0.1 mV</td> </tr> <tr> <td>4 V</td> <td>1 mV</td> </tr> <tr> <td>40 V</td> <td>10 mV</td> </tr> <tr> <td>400 V</td> <td>100 mV</td> </tr> <tr> <td>600 V</td> <td>1 V</td> </tr> </tbody> </table> <p>Autorange not available on 400.0 mV range</p>	Range	Resolution	400 mV	0.1 mV	4 V	1 mV	40 V	10 mV	400 V	100 mV	600 V	1 V	•	•	•		
Range	Resolution																	
400 mV	0.1 mV																	
4 V	1 mV																	
40 V	10 mV																	
400 V	100 mV																	
600 V	1 V																	
Accuracy	$\pm(2\%$ of reading + 5 counts) for 50 or 60 Hz sine wave. Add 2% of reading plus 5 counts for nonsinusoidal signal with crest factor <3.	•	•	•														
Ω/resistance																		
Range and Resolution	<table border="1"> <thead> <tr> <th>Range</th> <th>Resolution</th> </tr> </thead> <tbody> <tr> <td>400 Ω</td> <td>0.1 Ω</td> </tr> <tr> <td>4 kΩ</td> <td>1 Ω</td> </tr> <tr> <td>40 kΩ</td> <td>10 Ω</td> </tr> <tr> <td>400 kΩ</td> <td>100 Ω</td> </tr> <tr> <td>4 MΩ</td> <td>1 kΩ</td> </tr> <tr> <td>40 MΩ</td> <td>10 kΩ</td> </tr> </tbody> </table> <p>Autorange available</p>	Range	Resolution	400 Ω	0.1 Ω	4 k Ω	1 Ω	40 k Ω	10 Ω	400 k Ω	100 Ω	4 M Ω	1 k Ω	40 M Ω	10 k Ω	•	•	•
Range	Resolution																	
400 Ω	0.1 Ω																	
4 k Ω	1 Ω																	
40 k Ω	10 Ω																	
400 k Ω	100 Ω																	
4 M Ω	1 k Ω																	
40 M Ω	10 k Ω																	
Accuracy	$\pm(0.5\%$ of reading + 2 counts). 40 M Ω range is $\pm(2\%$ of reading +5 counts) at $\leq 60\%$ relative humidity. Derate 4 M Ω range to $\pm(1\%$ of reading + 2 counts) from 60% to 90% relative humidity.	•	•	•														

Table 2: DMM specifications (cont.)

550 | 560 | 565

Diode test		550	560	565
Range	0 to 2 V. Red input connector is positive.	•	•	•
Continuity check		550	560	565
Indication	Audible tone and graphic of a closed switch displayed when resistance is <50 Ω (typical). Indicators optionally disabled.	•	•	•

Table 3: Scope specifications

550 | 560 | 565

Modes		550	560	565
Autorange (Typical)	Autorange mode positions and sets the vertical and horizontal scales to between 30% and 60% of full screen. After 500 ms, the process repeats if the signal amplitude or period changes. The lower limits of Autorange are 50 mV/div and 100 ms/div. Autorange is the default mode.	•	•	•
Manual	The scope switches to manual operation when any control alters the waveform display.	•	•	•
Line Test	<ul style="list-style-type: none"> ■ Will monitor a 45 to 65 Hz power waveform on CH 1 and check for variations in amplitude and frequency. Abnormal events, such as spikes, drop-outs, and substantial frequency variations, will be captured and counted. ■ Automatic print of failures ■ Automatic screen save on failures ■ Time and date stamp on failure 		• • 1	• • 8
Motor Test	Will stabilize (trigger) on pulse-width modulated signals generated by variable-speed AC motor drives.			•
Vertical		550	560	565
Channels	Each channel is identical.	1	2	2
Probe Interface	Shrouded banana jack. Accepts 4 mm caged-spring safety style banana plug. Use probes incorporating 9 leaf-spring contacts only.	•	•	•
Digitizers	8 bits, 25 Msamples/s	1	2	2
Volts/Division Range	5 mV/div to 500 V/div in a 1-2-5 sequence	•	•	•
Modes	Normal and Invert	•	•	•
Coupling	DC, AC, COM (COM simulated)	•	•	•
Input Impedance	DC Coupled ≤ 10 pF: ≥ 975 k Ω	•	•	•
Analog Bandwidth	5 mV/div: DC to 1 MHz 10 mV/div to 2 V/div: DC to 5 MHz 5 to 500 V/div: DC to 1 MHz	•	•	•
Maximum Input Voltage	600 V _{RMS}	•	•	•
DC Accuracy (ΔV)	$\pm(3.5\% + 2 \text{ pixels})$ 19° to 27° C; derate by 0.25% per °C outside the range. Derate additional 0.5% at 5 mV/div. Linear range is ± 8 divisions from COM (common).	•	•	•
Crosstalk Between Channels	$\geq 100:1$ at 5 MHz, with other channel connected to COM (common)		•	•

Table 3: Scope specifications (cont.)

		550	560	565
Vertical				
Mathematics	Subtract: (CH 1 – CH 2) Add: (CH 1 + CH 2)		•	•
Acquisition				
Modes	Sample (Normal), Spike Detect, Roll, Run/Hold, Smooth, Dynamic DSP	•	•	•
Acquisition Rate	All modes except Dynamic DSP: Up to five waveforms per second Dynamic DSP Mode: Up to 750 waveforms per second (redisplayed at a slower rate.)	•	•	•
Horizontal				
Time/Division Range	60 s/div to 200 ns/div in a 1-2-5 sequence	•	•	•
Time Base Accuracy	±(0.1% + 1 pixel)	•	•	•
Record Length	256 points	•	•	•
Spike Detect	Captures spikes down to 40 ns at all sweep speeds	•	•	•
Single Shot	Single shot on two channels simultaneously	•	•	•
Roll	200 ms/div to 60 s/div	•	•	•
Measurements				
Cursors	Voltage difference between cursors (ΔV) Time difference between cursors (ΔT) Reciprocal of ΔT in Hertz ($1/\Delta T$)	•	•	•
Voltage and Amperes	For voltage or current probes: Maximum (MAX), Minimum (MIN), Peak-Peak (P-P)	•	•	•
Timing	Frequency (FREQ), Period (PER)	•	•	•
Power	Calculates true RMS current, voltage, true power, and power factor from CH 1 current (using current probe) and CH 2 voltage.		•	•
THDF	(Transformer Harmonic Derating Factor) calculated as [(RMS Current × 1.41414) ÷ Peak Current], read from a current probe on CH 1.		•	•
Trigger				
Source	CH 1 (Default)	•	•	•
	CH 2		•	•
Modes	Auto-Level: Default when in AutoRange mode Auto: Default in manual operation Normal: User selectable Single-Shot: User selectable	•	•	•
Slope	Positive or Negative slope	•	•	•
Sensitivity, Edge-type DC Coupled	0.5 division: 200 to 500 V/div 1 division: 10 to 100 mV/div 2 divisions: 5 mV/div	•	•	•

Table 3: Scope specifications (cont.)

		550	560	565
Waveform display				
Display Update Rate	Dynamic Display Digital Signal Processing maps up to 750 waveforms/s on screen, simulating an analog-like display.	•	•	•
Memories				
Setups	Each setup memory stores the complete state of the instrument, including the multimeter state.	4	4	8
Waveforms	Each waveform memory stores all waveform points and the scale of the selected waveform.	4	4	8
Screens	Each screen memory stores the exact information displayed on screen (snapshot).	1	1	8

Table 4: General specifications

		550	560	565
Clock				
Real Time	Provides date and time stamp capability for line test events and saved waveforms.	•	•	•
Display system				
Display Type	Super Twisted Liquid Crystal Display	•	•	•
Size	Width: 120 mm (4.72 inch) Height: 60 mm (2.36 inch)	•	•	•
Display Resolution	256 pixels horizontal × 128 pixels vertical	•	•	•
Contrast	User adjustable	•	•	•
Backlight	Electroluminescent			•
Waveform Graticule	8 divisions vertical × 10 divisions horizontal Default = crosshair, grid, or none 1 vertical division = 15 pixels 1 horizontal division = 25 pixels	•	•	•
Power source				
Batteries	Six AA cells (9 V nominal)	•	•	•
Battery Life (Typical)	4.5 hours continuous operation with alkaline cells (backlight off). Tested using RAYOVAC® Alkaline MAXIMUM™ batteries. Battery life extended when used intermittently.	•	•	•
Battery Saver	User adjusted battery saver feature turns the instrument off after five minutes and the backlight off after one minute.	•	•	•
Memory Retention Time	Memory hold-up time following battery removal: eight minutes minimum, three hours typical. Memory retention extended (weeks or months) if discharged batteries remain installed.	•	•	•

Table 4: General specifications (cont.)

		550	560	565
Environmental				
Temperature	Operating: 0° to 50° C (32° to 122° F) Storage: -20° to +70° C (-4° to 158° F)	•	•	•
Humidity, Operating	0° to 40° C (32° to 104° F): Up to 90% relative humidity noncondensing (60% for 4 and 40 MΩ measurements) 41° to 50° C (106° to 122° F): 60% relative humidity noncondensing.	•	•	•
Altitude	Operating:: 2,200 m (7,221 ft) Storage:: 12,192 m (40,000 ft)	•	•	•
Random Vibration	5 to 500 Hz, 10 min/axis, operating: 2.66 g _{RMS} 5 to 500 Hz, 10 min/axis, nonoperating: 3.48 g _{RMS}	•	•	•
Sine Vibration	Operating: 0.06 inch displacement from 5 to 15 Hz 0.04 inch displacement from 15 to 25 Hz 0.02 inch displacement from 25 to 55 Hz Test Duration: 10 minutes at the peak resonance condition (33 Hz if no resonance found). Test performed on each of three axes.	•	•	•
Half-sine Shock	Operating: 30 g with pulse duration of 11 ms. Three shocks per axis. Test Duration: 10 minutes at the peak resonance condition (33 Hz if no resonance found). Test performed on each of three axes.	•	•	•
EMC				
Emissions	EN 55011 radiated, class A	•	•	•
Immunity	IEC 801-2 electrostatic discharge: Up to 8 kV IEC 801-3 radiated immunity: 3 V/meter, 27 to 500 MHz	•	•	•
Mechanical				
Size	140 mm (5.5 inch) high × 210 mm (8.3 inch) wide × 43 mm (1.7 inch) deep	•	•	•
Weight	1 kg (2.2 lb) with Alkaline batteries installed	•	•	•
Tripod Socket	0.25 inch × 20 thread × 6.3 mm (0.25 inch) deep	•	•	•
Safety				
Certifications	Listed UL 3111-1 for 600 V CAT II measurements; CSA-C22.2 No 1010.1-92	•	•	•
Surge Protection	Withstands incidental line surges up to 6 kV (comprised of a minimum rise time of 1.2 μs and a maximum 50 μs duration, minimum of 2 minutes between pulses). Maximum volt-hertz product: 50 V-MHz.	•	•	•
Fuse	The instrument has no user-replaceable fuses	•	•	•
General	Safety Class 2	•	•	•

THM500 Series Performance Verification

This section contains procedures to verify that the THM500 Series instruments perform as warranted. Verify instrument performance whenever the accuracy or function of your instrument is in question.

The performance verification procedures provide a valid confirmation of instrument electrical characteristics and function under the following conditions:

- The instrument operates within the environmental conditions specified in Table 4 on page 8 during the verification process.
- The instrument operates continuously for a 5 minute period before the verification begins.

The performance verification procedure should be performed annually or after every 2000 hours of operation if used infrequently.

Table 6 lists the equipment needed to complete the performance verification procedures.

The THM500 Series performance verification consists of the checks listed in Table 5.

Table 5: Performance verification checks

Functional Test
DMM Verification
DC Voltage Accuracy
AC Voltage Accuracy
Resistance Accuracy
Oscilloscope Verification
Noise
Input Leakage Trace Shift
Time Base Accuracy
Vertical Accuracy
Analog Bandwidth
Crosstalk from DMM to Oscilloscope
Crosstalk Between Oscilloscope Channels
DC Offset

Test Equipment

The performance verification procedures use external traceable test equipment to directly check warranted characteristics.

Alternative test equipment must meet or exceed the intended minimum requirements specified in Table 6. If you substitute equipment, you may need to modify the procedures.

NOTE. Before beginning the performance verification procedures, warm up the test equipment according to the manufacturer's recommendations.

Table 6: Test equipment

Description	Minimum requirements	Example product
Leveled Sine Wave Generator	Output must provide 5 V into 50 Ω with 3% amplitude regulation at 50 kHz to 5 MHz	Wavetek 9100 Universal Calibration System with Oscilloscope Calibration Module (Option 250)
Time Mark Generator	Output must provide 1 μ s markers, $\pm 0.5\%$, at 1 V amplitude	Fluke 5500A Multi-product Calibrator with Oscilloscope Calibration Option 5500-SC
Calibrator		
DC Voltages	300 mV, 3 V, 30 V, 300 V, 500 V, with accuracy of $\pm 0.125\%$ or better	
AC Voltages	300 mV, 3 V, 30 V, 300 V, 500 V, with accuracy of $\pm 0.5\%$ or better	
Resistances	10 Ω , 100 Ω , 1 k Ω , 10 k Ω , 100 k Ω , 1 M Ω , with accuracy of $\pm 0.125\%$ or better	
Termination	50 Ω $\pm 2\%$, 2 W	Tektronix 011-0049-xx
BNC Cable	50 Ω , 1.04 m (42 inch) long	Tektronix 012-0057-xx
Safety Banana Lead Patch Cord		Tektronix 012-1413-xx
BNC Female-to-Dual-Banana Cable	Stacking banana connector	Tektronix 012-1450-xx
BNC Female-to-Dual-Banana Adapter		Tektronix 103-0090-xx

Functional Test

The following steps verify basic instrument operation and reset the THM500 series instruments to factory default settings.

1. Install fully charged batteries or use the THMCOM1 Communications Adapter or the THM5AC Power Adapter optional accessories to provide power.
2. Press the **ON/OFF** button to turn the THM500 series instrument on.
3. Press the **MENU ON/OFF** button to display the menus.

***NOTE.** The THM575 can display the menus in more than one language. The language selections are located in the Utility menu.*

4. Select **UTILITY►STATUS►DISPLAY** from the menus.
5. Press the **SELECT** button. Verify that the correct THM500 series instrument model number is displayed.
6. Use the menus to select **RESET ALL**. It will appear underlined.
7. Press the **SELECT** button and wait for the confirmation message; then press the **SELECT** button again.
8. Verify that the instrument returns to its power-on mode:
 - THM550, THM560, THM565, THM570, or THM570U instruments return to **METER** mode.
 - THM571, THM575, or THM570U Option 3K instruments return to a banner screen.

DMM Verification

The following checks verify the performance of the DMM functions. The oscilloscope verification begins on page 15.

NOTE. The THM575 can display menus in more than one language. The language selections are located in the Utility menu.

DC Voltage Accuracy

The following check verifies DC voltage accuracy.



WARNING. This test uses hazardous voltages. If you use standard banana plugs to apply test signals to the THM500 series instrument, do not touch the exposed conductors.

1. Set the THM500 series instrument to **METER** mode displaying **V-DC**. If the range display at the lower-right does not indicate **AUTO**, press the **▲** and **▼** buttons simultaneously to set the **RANGE** to **AUTO**.
2. Connect the voltage source output to the THM500 series instrument DMM and COM inputs as shown in Figure 2. Assure that the ground connection for each adapter connects to the common (or ground) connector of its associated instrument.
3. Set the voltage source for **DC** output.

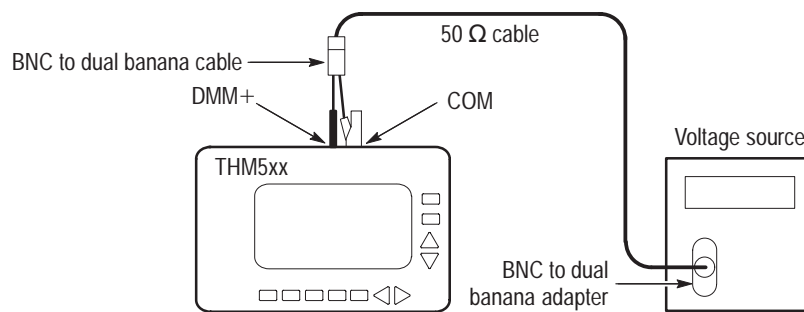

Figure 2: DC and AC voltage accuracy test setups

4. For each row of Table 7, use the **▲** and **▼** buttons to set the THM500 series instrument to the range specified in the first column; then set the voltage source to the output voltage specified in the second column. Verify that the THM500 series instrument readout is within the range listed in the third column.

Table 7: DC voltage accuracy test limits

Instrument range	DC voltage source	Instrument readout
400 mV	300 mV	298.0 to 302.0
4 V	3 V	2.980 to 3.020
40 V	30 V	29.80 to 30.20
400 V	300 V	298.0 to 302.0
850 V	500 V	492 to 508

AC Voltage Accuracy

The following check verifies AC voltage accuracy.



WARNING. This test uses hazardous voltages. If you use standard banana plugs to apply test signals to the THM500 series instrument, do not touch the exposed conductors.

1. Set the THM500 series instrument to **METER** mode displaying **V-AC**. If the range display at the lower-right corner does not indicate **AUTO**, press the **▲** and **▼** buttons simultaneously to set the **RANGE** to **AUTO**.
2. Set the voltage source to **60 Hz AC** output.
3. For each row of Table 8, use the **▲** and **▼** buttons to set the THM500 series instrument to the range specified in the first column; then set the voltage source to the output voltage specified in the second column. Verify that the THM500 series instrument readout is within the range listed in the third column.

Table 8: AC voltage accuracy test limits

Instrument range	AC voltage source at 60 Hz	Instrument readout
400 mV	300 mV	293.5 to 306.5
4 V	3 V	2.935 to 3.065
40 V	30 V	29.35 to 30.65
400 V	300 V	293.5 to 306.5
600 V	500 V	485 to 515

4. Set the calibrator output to a safe voltage (less than 20 V) and disconnect the THM500 series instrument from the calibrator.
5. Disconnect the test setup.

Resistance Accuracy

The following check verifies resistance accuracy.

1. Set the THM500 series instrument to **METER** mode displaying Ω . Connect the THM500 series instrument to the resistance source as shown in Figure 3.

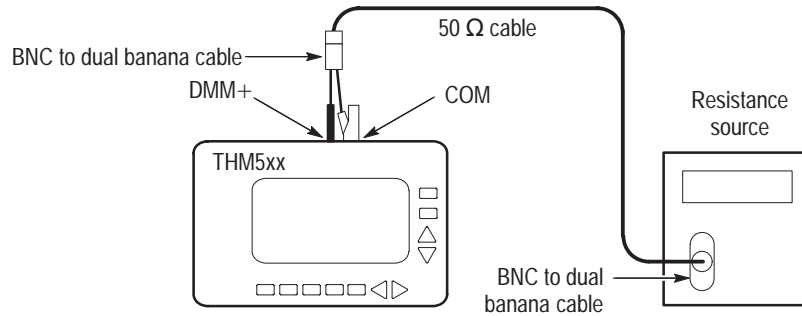

Figure 3: Resistance accuracy test setup

2. For each row of Table 9, use the \blacktriangle and \blacktriangledown buttons to set the THM500 series instrument to the range specified in the first column; then set the resistance source to the resistance specified in the second column. Verify that the THM500 series instrument readout is within the range listed in the third column.

Table 9: Resistance accuracy test limits

Instrument range	Resistance source	Instrument readout
400 Ω	100 Ω	99.3 to 100.7
4 k Ω	1 k Ω	0.993 to 1.007
40 k Ω	10 k Ω	9.93 to 10.07
400 k Ω	100 k Ω	99.3 to 100.7
4 M Ω	1 M Ω	0.993 to 1.007

3. Disconnect the test setup.
4. If you will not be performing the Oscilloscope Verification procedures, use the menus to return the THM500 series instrument to factory default settings by selecting **RESET ALL**.

Oscilloscope Verification

The following checks verify the performance of the oscilloscope functions. The DMM checks begin on page 12.

NOTE. The THM575 can display the menus in more than one language. The language selections are located in the Utility menu.

Noise The following check verifies an acceptable noise level.

1. Set the THM500 series instrument to **SCOPE** mode. If necessary, press the **SELECT** button to point to **CH 1**.
2. Use a patch cord to short the THM500 series instrument COM and CH 1 inputs as shown in Figure 4.

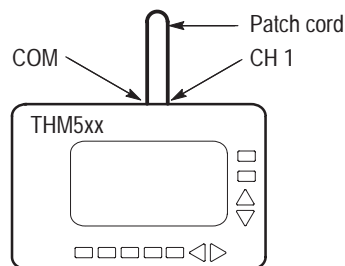

Figure 4: Noise test setup

3. Press the **SCALE** button until the readout in the lower-right corner indicates **SCALE**; then use the **▲** and **▼** buttons to set the vertical scale to **10 mV/div**.
4. Use the menus to set the sampling mode to **SPIKE DETECT**; then turn off the menus.
5. Verify that the displayed peak-to-peak signal is less than 0.5 divisions ($5 \text{ mV}_{\text{p-p}}$).
6. If your THM500 series instrument is equipped with two channels, repeat steps 2 through 5 above for CH 2.
7. Disconnect the test setup.

Input Leakage Trace Shift

The following check verifies an acceptable input leakage trace shift.

1. Use the THM500 series instrument menus to set the sampling mode to **SAMPLE** (NORMAL for the THM571); then turn the menus off.
2. Use a patch cord to short the COM and CH 1 inputs as shown in Figure 5.

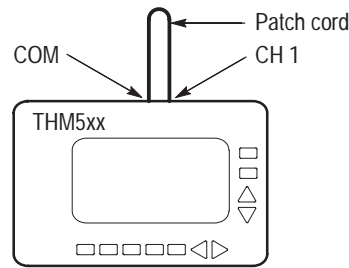

Figure 5: Trace shift test setup

3. Press the THM500 series instrument **POSITION/SCALE** button until the readout in the lower-right corner shows **SCALE**; then use the ▲ and ▼ buttons to set the vertical scale to **5 mV/div**.
4. Press the THM500 series instrument **POSITION/SCALE** button until the readout in the lower-right corner shows **POS**; then use the ▲ and ▼ buttons to position the trace vertically at the center of the display.
5. Verify that as you remove the shorting patch cord, the waveform does not move more than three pixels vertically.
6. If your THM500 series instrument is equipped with two channels, repeat steps 2 through 5 above for CH 2.
7. Disconnect the test setup.

Time Base Accuracy

The following check verifies the time base accuracy.

1. Connect the time mark generator marker output to the THM500 series instrument CH 1 and COM inputs using a 50 Ω termination as shown in Figure 6. Assure that the ground connection for each adapter connects to the common (or ground) connector of its associated instrument.
2. If necessary, press the THM500 series instrument **SELECT** button to point to **CH 1**.

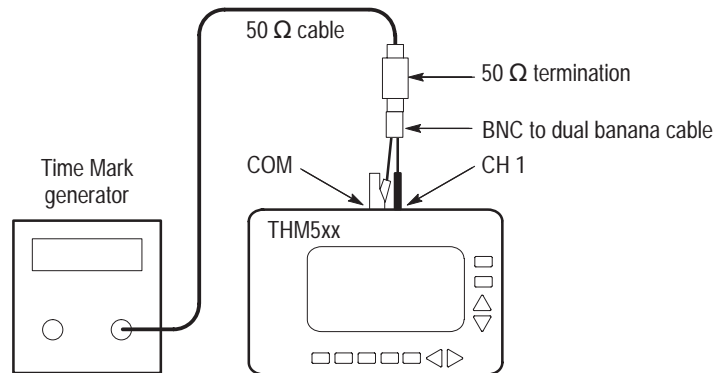

Figure 6: Time base accuracy test setup

3. Set the time mark generator for **1 μs** markers.
4. On the THM500 series instrument, press the **POSITION/SCALE** button until the readout shows **SCALE** in the lower-right corner. Use the **▲** and **▼** buttons to set the vertical scale to **200 mV/div**. Use the **◀** and **▶** buttons to set the time base to **1 μs/div**.
5. Use the THM500 series instrument menus to set **CH 1 CPLG** to **DC**; then turn the menus off.
6. Press the THM500 series instrument **CURSORS/TRIGGER** button until the readout shows **TRIG** in the lower-right corner; then use the **▲** and **▼** buttons to set the trigger level to one division above the bottom of the displayed signal. Use the **◀** or **▶** button to set the trigger to rising edge (**/**).
7. Press the THM500 series instrument **POSITION/SCALE** button until the readout shows **POS** in the lower-right corner; then use the **◀** button to set the trigger position to **10%**.
8. Verify that the THM500 series instrument rising edge of the fifth time mark is within one pixel of the center vertical graticule line, measured at one division above the bottom of the displayed signal.
9. Disconnect the test setup.

Vertical Accuracy

The following check verifies vertical accuracy.

1. Connect the voltage source output to the THM500 series instrument CH 1 and COM inputs as shown in Figure 7. Assure that the ground connection for each adapter connects to the common (or ground) connector of its associated instrument.

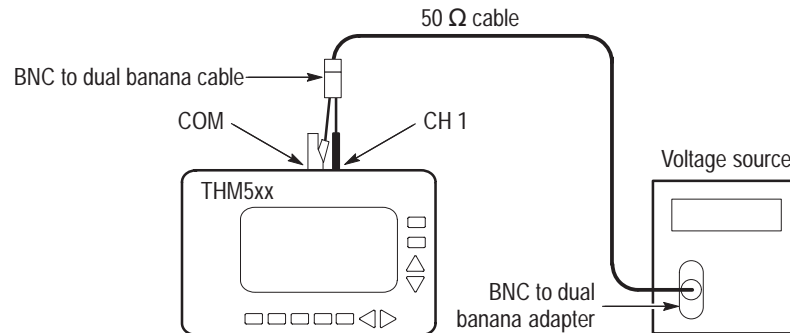

Figure 7: Vertical accuracy test setup

2. Use the menus to set the THM500 series instrument **CH 1 CPLG** to **DC**; then turn the menus off.



WARNING. This test uses hazardous voltages. If you use standard banana plugs to apply test signals to the THM500 series instrument, do not touch the exposed conductors.

3. For each row of Table 10, perform the following steps:
 - a. Use the THM500 series instrument **▲** and **▼** buttons to set the vertical scale to the setting listed in the first column.
 - b. Set the voltage source output to the value in the second column.
 - c. Press the THM500 series instrument **POSITION/SCALE** button to show **POS**; then use the **▲** and **▼** buttons to move the waveform three divisions below the center of the graticule.
 - d. Press the THM500 series instrument **CURSORS/TRIGGER** button to show the cursors; then use the **▲** and **▼** buttons to move one cursor over the waveform.
 - e. Set the voltage source output to the value in the third column, press the THM500 series instrument **SELECT** button to select the second cursor, and position the second cursor over the new waveform position.

- f. Observe the ΔV readout on the THM500 series instrument display and verify that its absolute value falls within the range listed in the fourth column.

Table 10: Vertical accuracy test settings

THM500 series vertical scale	DC voltage source (first cursor)	DC voltage source (second cursor)	Instrument ΔV readout (ignore polarity)
5 mV/div	-15mV	+15 mV	27.5mV to 32.5 mV
100mV/div	-300 mV	+300 mV	552 mV to 648 mV
1 V/div	-3 V	+3 V	5.52 V to 6.48 V
10V/div	-30 V	+30 V	55.2 V to 64.8 V
100V/div	-300 V	+300 V	552 V to 648 V

- 4. If your THM500 series instrument is equipped with two channels, repeat Step 3 (all tests) above on CH 2.
- 5. Disconnect the test setup.

Analog Bandwidth

The following check assesses the analog bandwidth.

- 1. Connect the leveled sine wave generator output to the THM500 series instrument CH 1 and COM inputs. Use a 50 Ω termination as shown in Figure 8. Assume that the ground connection for each adapter connects to the common (or ground) connector of its associated instrument.
- 2. Press the THM500 series instrument **CURSORS/TRIGGER** button until the readout shows **TRIG** in the lower-right corner; then use the **▲** and **▼** buttons to set the trigger level to center screen.

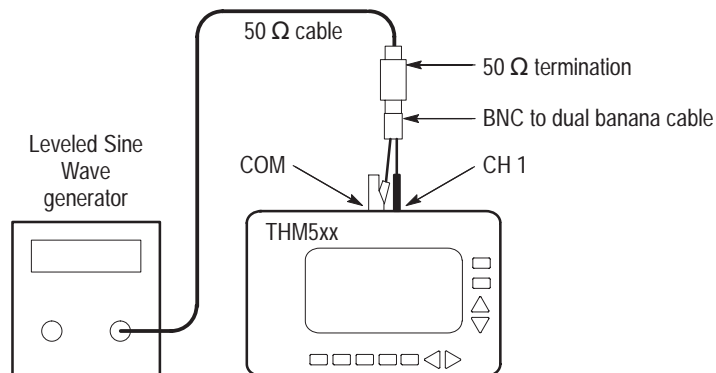

Figure 8: Analog bandwidth test setup

3. On the THM500 series instrument, press the **POSITION/SCALE** button until the readout shows **SCALE** in the lower-right corner.
4. For each row of Table 11, perform the following steps:
 - a. Use the THM500 series instrument **▲** and **▼** buttons to set the vertical scale to the setting listed in the first column.
 - b. Set the horizontal scale of the THM500 series instrument to **10 $\mu\text{s}/\text{div}$** and the frequency of the leveled sine wave generator to **50 kHz**.
 - c. Adjust the leveled sine wave generator amplitude to show the waveform height and cursor readout listed in the second column.
 - d. Set the horizontal scale of the THM500 series instrument to **200 $\mu\text{s}/\text{div}$** and the leveled sine wave generator to the test frequency listed in the third column.
 - e. Verify that the amplitude of the waveform displayed on the THM500 series instrument is greater than or equal to the value listed in the third column. Use the cursors for greater accuracy.

Table 11: Bandwidth test settings

THM500 series vertical scale	Leveled sine wave generator amplitude	Leveled sine wave generator test frequency	Instrument waveform amplitude
100 mV/div	6 divisions (600 mV _{p-p} readout)	5 MHz	4.2 divisions ¹ (420 mV cursor readout)
500 mV/div	6 divisions (3.00 V _{p-p} readout)	5 MHz	4.2 divisions ¹ (2.1 V cursor readout)
5 V/div	1 division (5.00 V _{p-p} readout)	1 MHz	0.7 divisions ¹ (3.5 V cursor readout)

¹ The waveform is aliased and appears untriggered.

5. If your THM500 series instrument is equipped with two channels, repeat Step 4 above on CH 2 (all tests).
6. Disconnect the test setup.

Crosstalk from DMM to Oscilloscope

The following check assesses the crosstalk between the DMM and the oscilloscope.

1. Connect the leveled sine wave generator output to the THM500 series instrument DMM and COM inputs. Use a 50 Ω termination as shown in Figure 9. Assure that the ground connection for each adapter connects to the common (or ground) connector of its associated instrument.

2. Connect the THM500 series instrument CH 1 input to the COM input using a patch cord as shown in Figure 9.

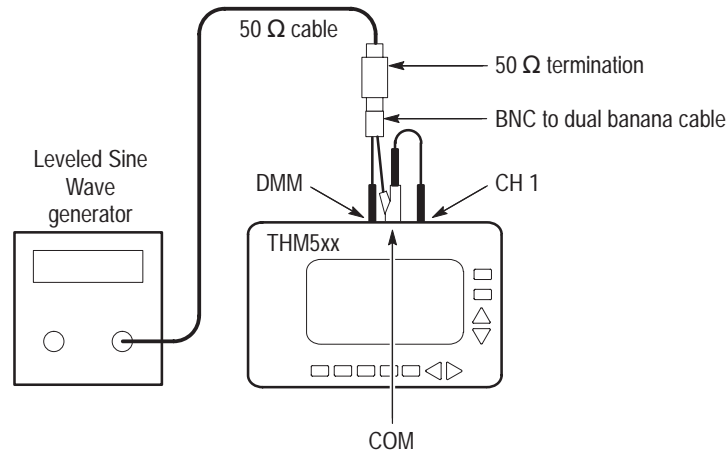

Figure 9: Crosstalk between DMM and scope test Setup

3. Set the leveled sine wave generator for a $2.5 V_{p-p}$ signal at **5 MHz**.
4. On the THM500 series instrument, press the **POSITION/SCALE** button until the readout shows **SCALE** in the lower-right corner. Use the **▲** and **▼** buttons to set the vertical scale to **50 mV/div** and the **◀** and **▶** buttons to set the time base to **2000 μ s/div**.
5. Use the THM500 series instrument menus to set the sampling mode to **SPIKE DETECT**; then remove the menus from the display.
6. Verify that the peak-to-peak amplitude is less than 0.5 divisions ($25 mV_{p-p}$).

Crosstalk Between Oscilloscope Channels

The following check assesses the crosstalk between oscilloscope channels. If your instrument has only one channel (THM550), do not perform this test.

1. Connect the leveled sine wave generator output to the THM500 series instrument CH 1 and COM inputs. Use a 50Ω termination as shown in Figure 10. Assure that the ground connection for each adapter connects to the common (or ground) connector of its associated instrument.
2. Connect the THM500 series instrument CH 2 input to the COM input using a patch cord as shown in Figure 10.

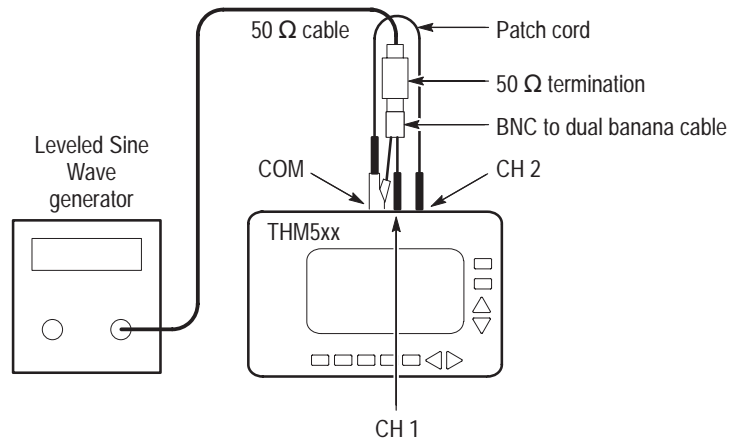

Figure 10: Crosstalk between scope channels test setup

3. On the THM500 series instrument, press the **POSITION/SCALE** button until the readout shows **SCALE** in the lower-right corner. Use the ▲ and ▼ buttons to set the CH 1 vertical scale to **500 mV/div** and the ◀ and ▶ buttons to set the time base to **200 μs/div**.
4. Use the THM500 series instrument menus to set the sampling mode to **SPIKE DETECT**; then remove the menus from the display.
5. Adjust the leveled sine wave generator to display five divisions peak-to-peak at **5 MHz**.

NOTE. The 5 MHz waveform is aliased and appears untriggered.

6. Press the THM500 series instrument **WAVEFORM ON/OFF** button to turn the CH 1 waveform display off.
7. Press the THM500 series instrument **SELECT** button to select **CH 2**. Press the **WAVEFORM ON/OFF** button to turn on channel 2. Press the **POSITION/SCALE** button to show **SCALE**; then use the ▲ and ▼ buttons to set the vertical scale to **50 mV/div**.
8. Verify that the peak-to-peak signal displayed on the THM500 series instrument channel 2 is less than 0.5 divisions (25 mV_{p-p}).
9. Disconnect the test setup.

DC Offset The following check assesses the DC offset.

1. Use the THM500 series instrument menus to select **RESET ALL**. This sets the vertical position to zero.
2. Return the THM500 series instrument to **SCOPE** mode.
3. Use the THM500 series instrument **UTILITY** menu to select **CH 1 OFFSET**. This automatically adjusts the channel offset.
4. Use a patch cord to short the THM500 series instrument COM and CH 1 inputs as shown in Figure 11.

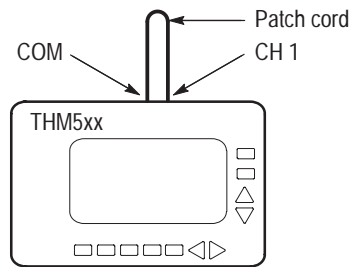

Figure 11: DC offset test setup

5. Press the THM500 series instrument **POSITION/SCALE** button until the readout shows **SCALE** in the lower-right corner; then use the **▲** and **▼** buttons to set the CH 1 vertical scale to **5 mV/div**.
6. Verify that the offset is less than four pixels from the center graticule line.
7. Use the **▲** and **▼** buttons to set the vertical scale to the next range.
8. Repeat steps 6 through 7 above until you have checked all ranges (10 mV/div through 500 V/div).
9. If your THM500 series instrument is equipped with two channels, repeat steps 3 through 8 above for CH 2.
10. Disconnect the test setup.
11. Use the menus to return the THM500 series instrument to the factory default settings; select **RESET ALL**.

NOTE. Return THM575 products to the initial language selection (if you changed the language selection). You will find these selections in the Utility menu.
